

LOMAX[®] SYSTEM

MODULAR HOARDING AND FENCING SOLUTIONS
COMPACT | REUSABLE | FREESTANDING

INSTALLATION AND TECHNICAL GUIDE

For all enquiries, please contact us:

1300 0 LOMAX

1 3 0 0 0 5 6 6 2 9

lomaxsystem.com

Components



LOMAX STANDARD COUNTERWEIGHT (HOARDING AND FENCING APPLICATIONS)

- 90x45mm (4x2) recess designed to receive either a vertical hoarding timber stud or a fencing support post
- Integrated metal plates to retain either the timber stud or the fencing support post
- 32mm OD holes to receive hoarding support posts or fencing panels
- Horizontal track to receive hoarding crossbeam support timbers
- Easy carry handles
- Interlocking shape for secure stacking
- 18Kg weight

HOARDING COMPONENTS

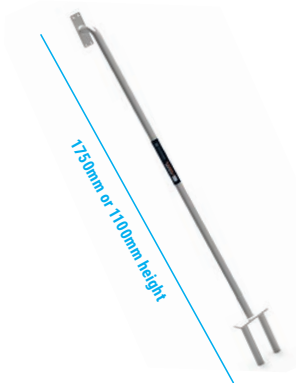

LOMAX SUPPORT POSTS - LARGE AND SMALL

- 2 x 32mm OD guide-prongs to slide into Full Sized Counterweight
- Galvanised steel construction for strength and durability
- Easy to stack, store and transport
- 5Kg weight



LOMAX DOUBLE SUPPORT POSTS

- 4 x 32mm OD guide-prongs to slide into double stacked Full Sized Counterweights
- Galvanised steel construction for strength and durability
- Easy to stack, store and transport
- 9Kg weight

FENCING COMPONENTS

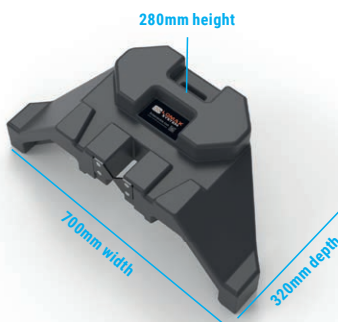

LOMAX SADDLE COUNTERWEIGHT

- 90x45mm (4x2) recess designed to receive fencing support post
- Integrated metal plates to retain the fencing support post
- Easy carry handles
- Interlocking shape for secure stacking on top of the Standard Counterweight
- 30Kg weight



LOMAX FENCING SUPPORT POSTS

- 90x45mm (4x2) shaped base to fit into the recess in the Counterweights
- Integrated panel clamp (separate loose clamp not required)
- Galvanised steel construction for strength and durability
- Easy to stack, store and transport
- 5Kg weight

Indoor Impact-Rated Hoarding: 1.8mH – 6mH

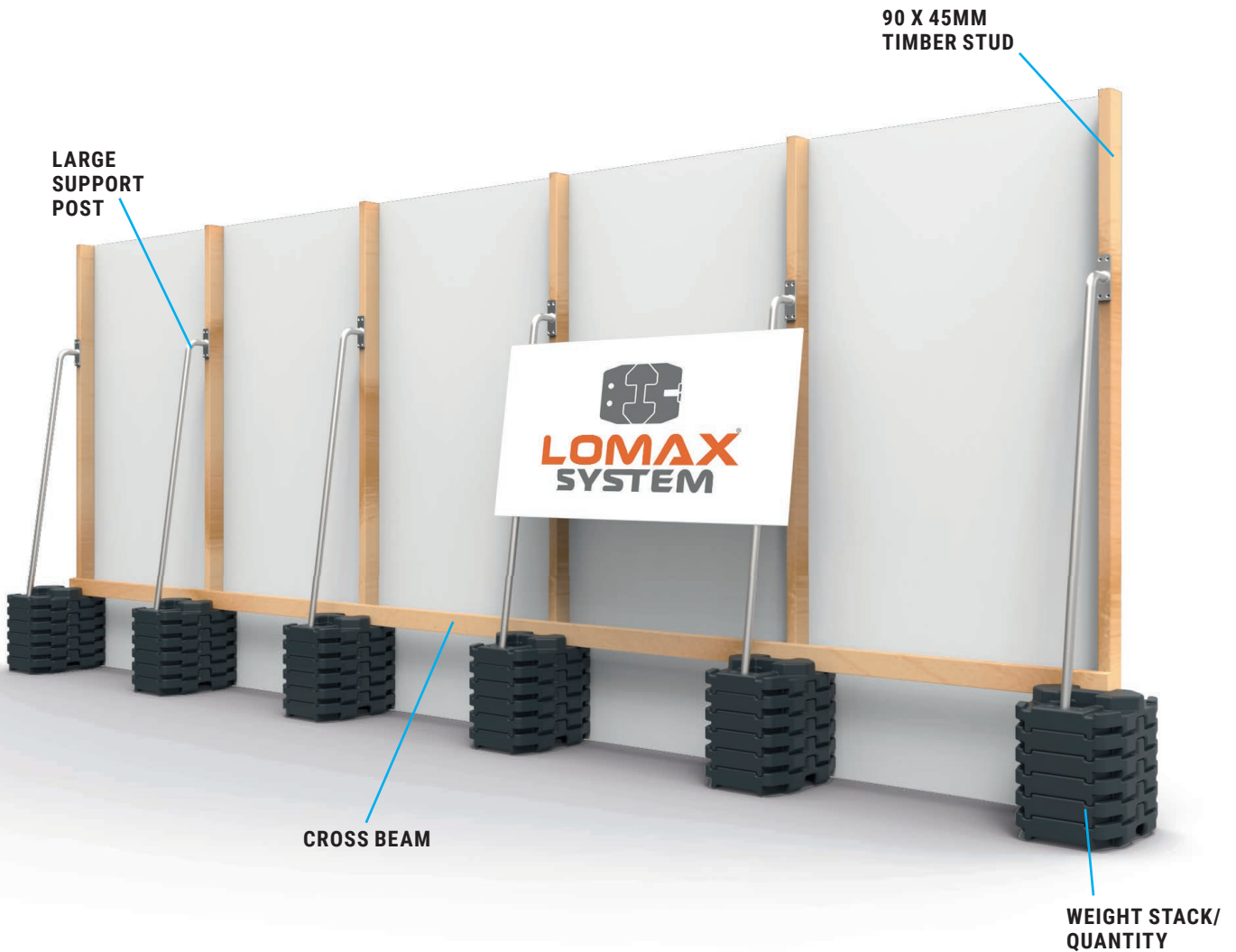

INDOOR HOARDING 'WEIGHT TO HEIGHT' GUIDE FOR COMPLIANCE TO AS4687

SOLID PANEL HEIGHT – MAX (H)	STUD – 90 X 45 (4X2) MPG10	QUANTITY OF COUNTER-WEIGHTS PER STACK	MAX INTERVAL BETWEEN COUNTER-WEIGHT STACKS	CEILING, FLOOR OR SIDE BRACING REQUIREMENTS
1.2m	90 x 45 MPG10	2	2.4mW	Freestanding – Not Required
1.8m	90 x 45 MPG10	3	1.2mW	Freestanding – Not Required
2.4m	90 x 45 MPG10	3	1.2mW	Freestanding – Not Required
3m	90 x 45 MPG10	4	1.2mW	Freestanding – Not Required
3.6m	90 x 45 MPG10	4	1.2mW	Freestanding – Not Required
4m	90 x 45 MPG10	5	1.2mW	Freestanding – Not Required
4.6m	90 x 45 MPG10	6	1.2mW	Freestanding – Not Required
5m	90 x 45 MPG10	8	1.2mW	Freestanding – Not Required
5.6m	90 x 45 MPG10	10	1.2mW	Freestanding – Not Required
6m	90 x 45 MPG10	12	1.2mW	Freestanding – Not Required

Lower Cross-Brace and Support Post Required for all Certification – See LOMAX for Technical Guide / Build Process

BUILD GUIDE FOR INDOOR AND OUTDOOR 'SINGLE STACK' HOARDINGS UP TO 6MH



1. Stack Lomax® counter-weights



2. Insert standard 90x45 (4x2) MPG 10 stud (non-ribbed)



3. Insert Lomax® Support Post



4. Attach panels



5. Add cross beam

ABOVE GUIDE IS FOR 'SINGLE WEIGHT STACK' CONFIGURATIONS ONLY. ADDITIONAL PRE-CERTIFIED 'DOUBLE STACK' CONFIGURATIONS ARE AVAILABLE. PLEASE CONTACT LOMAX HOARDING AND FENCING FOR TECHNICAL GUIDANCE.

HOARDING SYSTEM SPECIFICATIONS + REQUIREMENTS

DETAILS	COMMENTS
All Configurations Designed + Structural Engineer Tested to:	Indoor Impact tested: AS 4687:2022
Panel Height Options (All Freestanding)	Indoor: 1.2mH – 8mH + Outdoor: 1.2mH – 4mH
Panel Thickness Options	Min 12mm required
Panel Type Options	Mdf, Particle, Ply, Melamine, EPS
Min Quantity of panels needed for certification	3
Lomax Counterweight (Kg)	Approx 18Kg each
Stack types	Single or Double – See various illustrations
Double Stack Safety Rod (Only one per rear stack required)	10mm rod / 50mm washer top and bottom / Bottom lock nut (see separate rod height guide)
Stud Requirments: 1.2mH – 6mH (Indoor) + 1.2mH – 4mH (Outdoor)	Single vertical 90x45mm (4x2) MPG 10 (smooth / non-ribbed)
Stud Requirments: 6.1mH – 8mH (Indoor)	Double vertical 90x45mm (4x2) MPG 10 (smooth / non-ribbed) – See joining guidelines
No movement Crossbeam Stud Requirements: 1.2mH – 6mH	1 x horizontal 90x45mm (4x2) MPG 10 (smooth / non-ribbed) – see illustration
No movement Crossbeam Stud Requirements: 6.1mH – 8mH	2 x horizontal 90x45mm (4x2) MPG 10 (smooth / non-ribbed) – see illustration
Screw Requirments: 1.2mH – 6mH (Indoor) + 1.2mH – 4mH (Outdoor)	Min 40mm x 8g (to attach panels plus attach support post to vertical timber)
Screw Requirments 6.1mH – 8mH+ (Indoor)	Min 40mm x 8g (to attach panels) + 50mm x 12g (to attach support post to vertical timber)
Screw Spacing: 1.2mH – 6mH (Indoor) + 1.2mH – 4mH (Outdoor)	100mm from top and bottom of panels – then each 400mm-500mm in between
Screw Spacing 6.1mH – 8mH+ (Indoor)	100mm from top and bottom of panels – then each 400mm in between
Screw Spacing and requirments for stud joining	400mm Spacing – Staggered placement of 75mm x 14g Bugle (see illustration)

Indoor Impact-Rated Hoarding: 6.1mH – 8mH

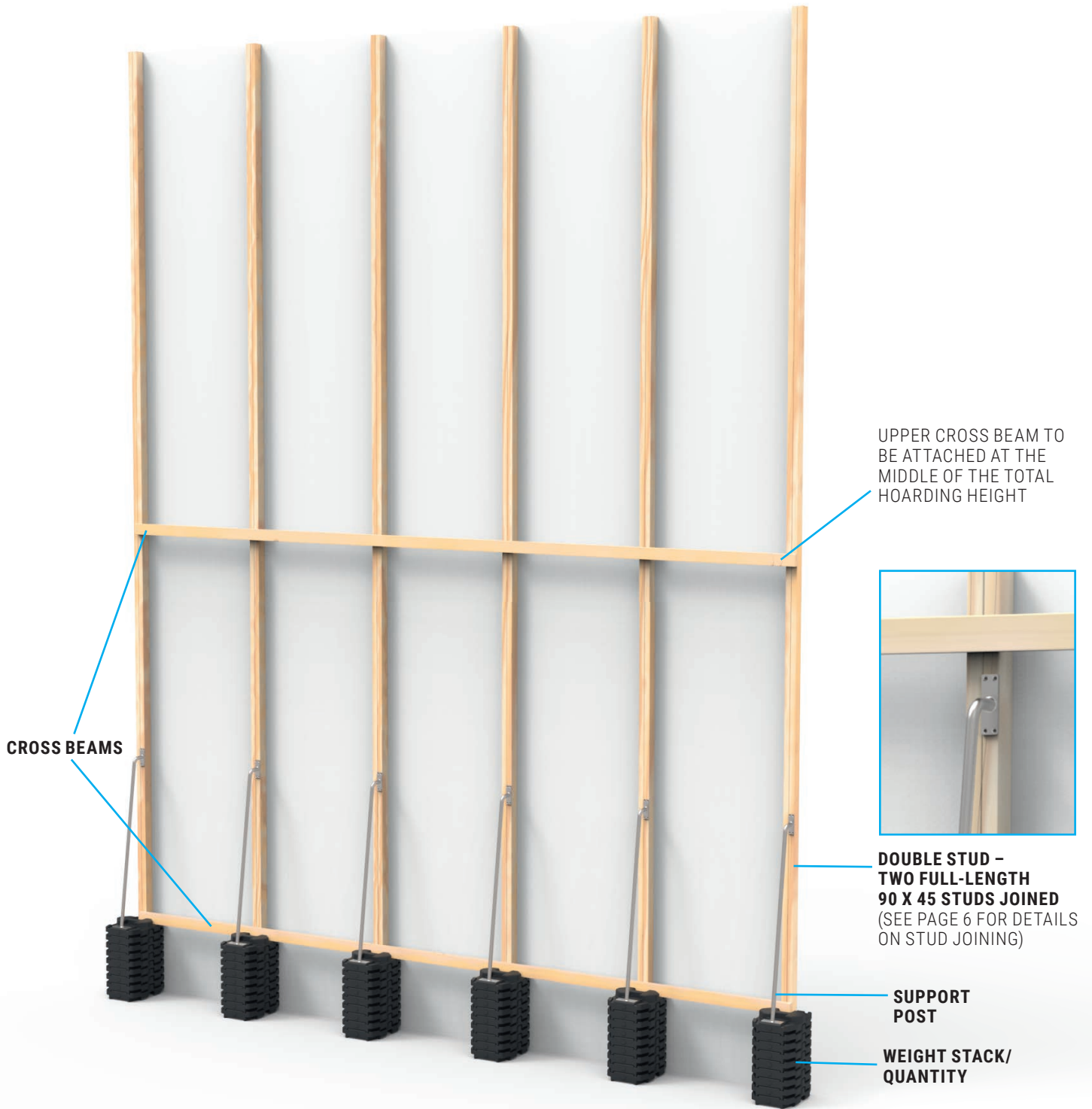

INDOOR HOARDING 'WEIGHT TO HEIGHT' GUIDE FOR COMPLIANCE TO AS4687

SOLID PANEL HEIGHT - MAX (H)	STUD - 90 X 45 (4X2) MPG10	QUANTITY OF COUNTER-WEIGHTS PER STACK	MAX INTERVAL BETWEEN COUNTER-WEIGHT STACKS	CEILING, FLOOR OR SIDE BRACING REQUIREMENTS
6.6m	90 x 45 MPG10	16	1.2mW	Freestanding - Not Required
7m	90 x 45 MPG10	16	1.2mW	Freestanding - Not Required
7.6m	90 x 45 MPG10	20	1.2mW	Freestanding - Not Required
8m	90 x 45 MPG10	20	1.2mW	Freestanding - Not Required

Lower Cross-Brace and Support Post Required for all Certification - See LOMAX for Technical Guide / Build Process

Stud Joining

JOIN A STUD

>6.1MH – 8MH HOARDING
FULL HEIGHT DOUBLE STUD
REQUIRED



EXTENDING A STUD

1.8MH – 6MH HOARDINGS
MIN 1.2M ABOVE / BELOW
OVERLAP OF JOIN REQUIRED
(MIN 2.4ML JOINING STUD)



SCREW SPACING

400MM SPACINGS – STAGGERED

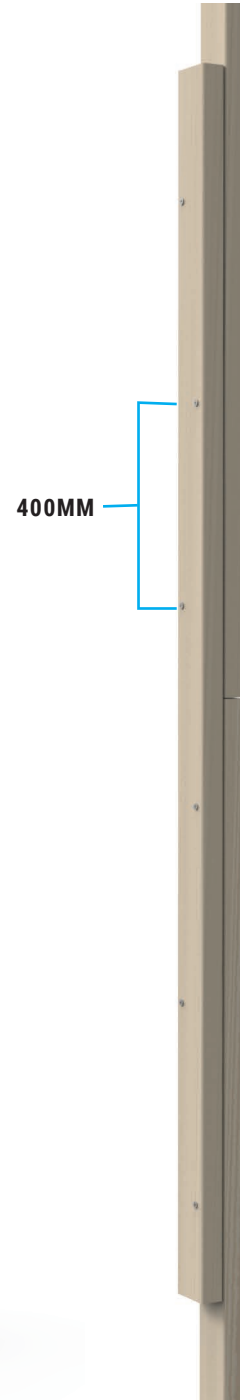

Door Fitting

Lower horizontal header timber to rest on vertical door jambs, just above doors

Lower header timber to be located just above doors / Upper header timber to be at the top of hoarding and then insert additional header timber every 400mm-500m in-between

Hinge location is recommended to be max 400mm from top and 400mm from bottom (min 2 hinges per side)

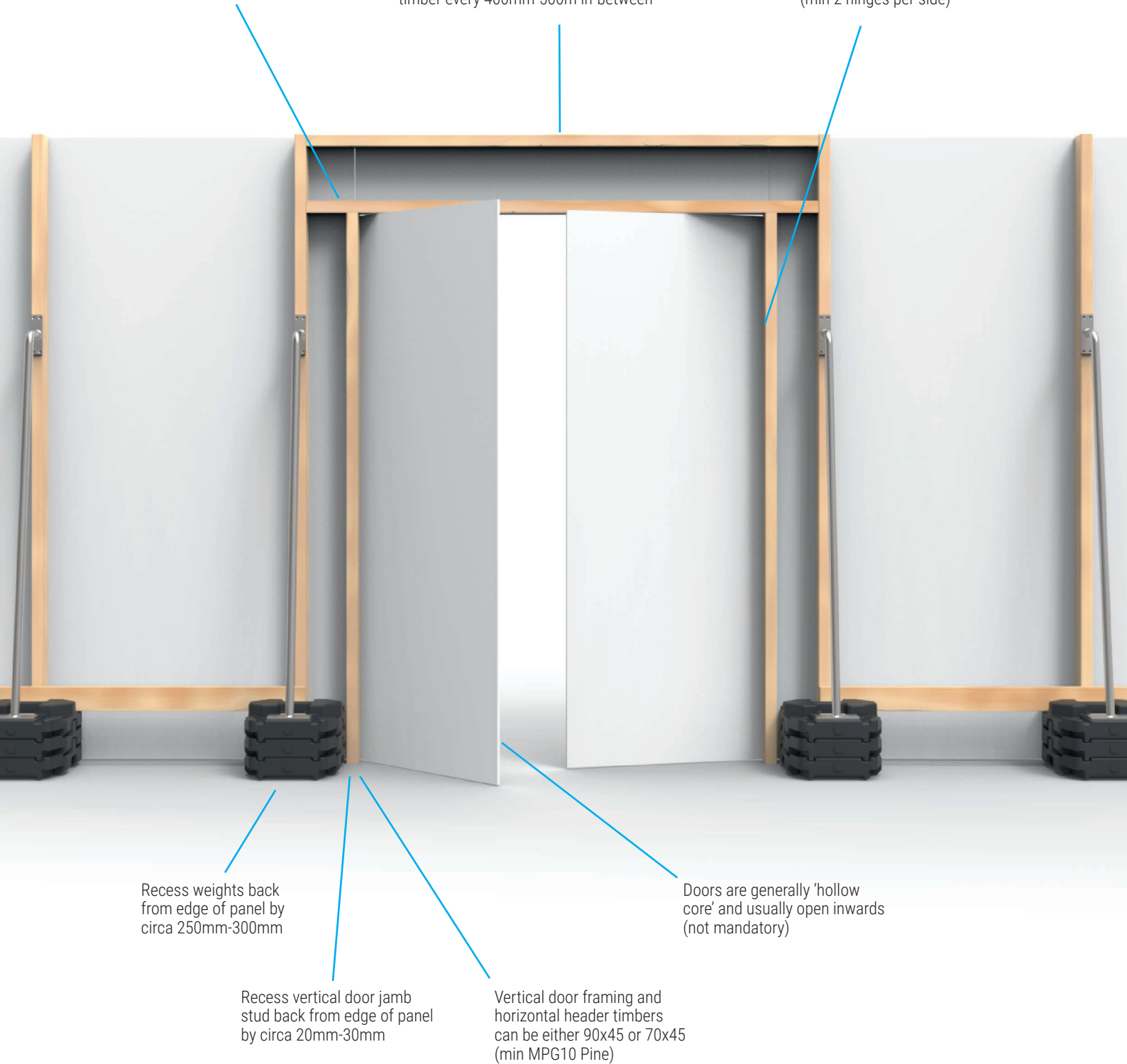

Recess weights back from edge of panel by circa 250mm-300mm

Recess vertical door jamb stud back from edge of panel by circa 20mm-30mm

Vertical door framing and horizontal header timbers can be either 90x45 or 70x45 (min MPG10 Pine)

Doors are generally 'hollow core' and usually open inwards (not mandatory)

ILLUSTRATION SHOWS 2.4MH INDOOR HOARDING WITH 2MH DOOR AND 0.4MH TOP PANEL

Kiosk

LOW HEIGHT PERIMETER (1.2MH)



CONTAINMENT PERIMETER (2.4MH)

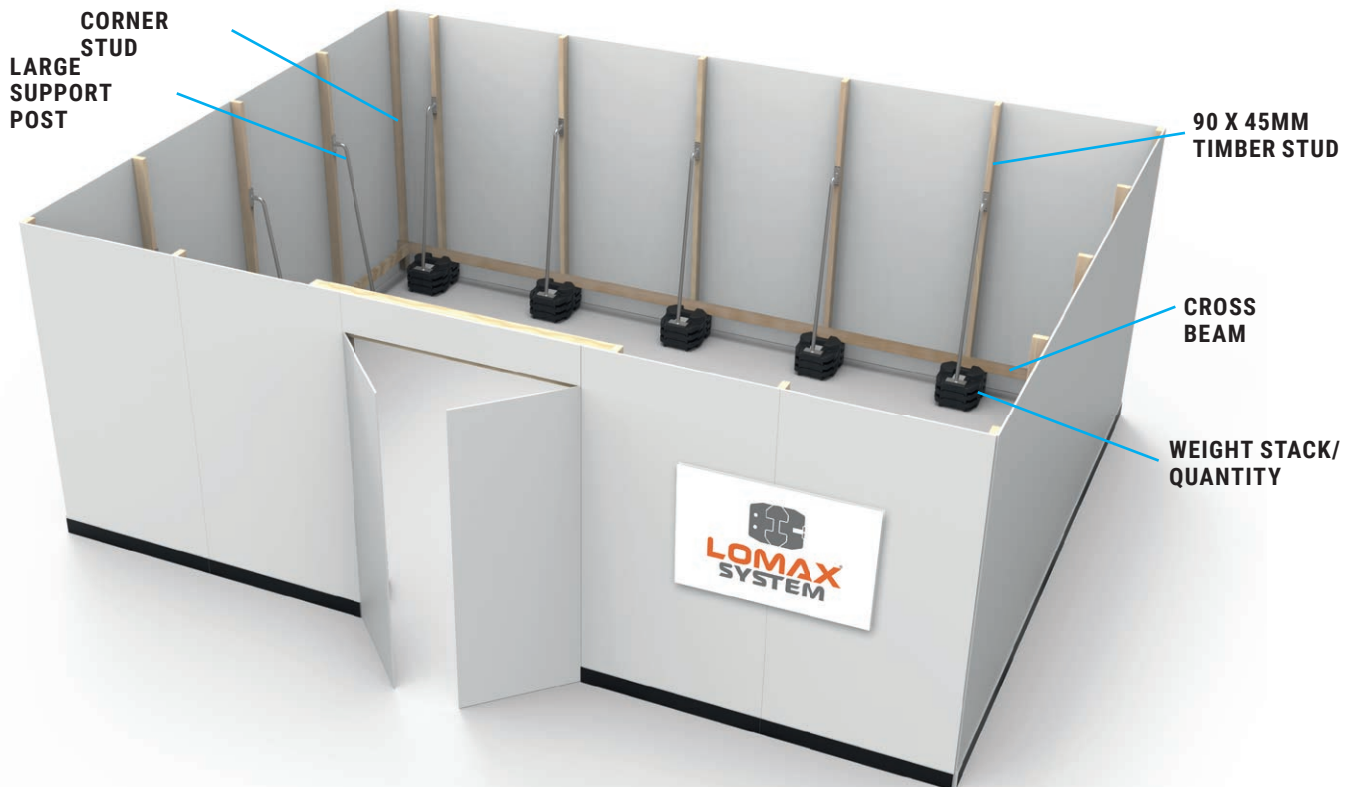

INDOOR HOARDING 'WEIGHT TO HEIGHT' GUIDE FOR COMPLIANCE TO AS4687

SOLID PANEL HEIGHT - MAX (H)	STUD - 90 X 45 (4X2) MPG10	QUANTITY OF COUNTER-WEIGHTS PER STACK	MAX INTERVAL BETWEEN COUNTER-WEIGHT STACKS	CEILING, FLOOR OR SIDE BRACING REQUIREMENTS
1.2m	91 x 45 MPG10	2	2.4mW	Freestanding - Not Required
2.4m	92 x 45 MPG10	3	1.2mW	Freestanding - Not Required

Lower Cross-Brace and Support Post Required for all Certification (Plus a 1.2mH kiosk requires top Cross-Brace)

Outdoor Wind Rated Hoarding

SINGLE STACK



OUTDOOR HOARDINGS – SINGLE STACK – 'WEIGHT / HEIGHT/ WIND SPEED' EXAMPLES

FREE-STANDING HOARDING OPTIONS FOR **SINGLE STACK OF COUNTERWEIGHTS @ 1.2MW INTERVALS**

SOLID PANEL HEIGHT – MAX (H)	STUD – 90 X 45 (4X2) MPG10	WIND SPEED 10M/S (36KPH)	WIND SPEED 11M/S (39.6KPH)	WIND SPEED 12M/S (43.2KPH)	WIND SPEED 13M/S (46.8KPH)	WIND SPEED 14M/S (50.4KPH)	WIND SPEED 15M/S (54KPH)
1.8m	90 x 45 MPG10	3	3	4	5	6	7
2.4m	90 x 45 MPG10	5	6	8	10	11	13
3m	90 x 45 MPG10	8	10	13	15	18	N/A
3.6m	90 x 45 MPG10	12	15	19	N/A	N/A	N/A
4m	90 x 45 MPG10	15	19	N/A	N/A	N/A	N/A

FREE-STANDING HOARDING OPTIONS FOR **SINGLE STACK OF COUNTERWEIGHTS @ 0.6MW INTERVALS**

SOLID PANEL HEIGHT – MAX (H)	STUD – 90 X 45 (4X2) MPG10	WIND SPEED 10M/S (36KPH)	WIND SPEED 13M/S (46.8KPH)	WIND SPEED 15M/S (54KPH)	WIND SPEED 19M/S (68.4KPH)	WIND SPEED 21M/S (75.6KPH)	WIND SPEED 23M/S (82.8KPH)
1.8m	90 x 45 MPG10	3	3	4	6	8	10
2.4m	90 x 45 MPG10	3	5	7	12	14	17
3m	90 x 45 MPG10	4	8	11	18	N/A	N/A
3.6m	90 x 45 MPG10	6	12	16	N/A	N/A	N/A
4m	90 x 45 MPG10	8	14	20	N/A	N/A	N/A

See 'Lomax System Outdoor Configurator' for full range of options

Outdoor Wind Rated Hoarding

DOUBLE STACK



OUTDOOR HOARDINGS – DOUBLE STACK – ‘WEIGHT / HEIGHT/ WIND SPEED’ EXAMPLES

FREE-STANDING HOARDING OPTIONS FOR **DOUBLE STACK OF COUNTERWEIGHTS @ 1.2MW INTERVALS**

SOLID PANEL HEIGHT – MAX (H)	STUD – 90 X 45 (4X2) MPG10	WIND SPEED 15M/S (54KPH)	WIND SPEED 19M/S (68.4KPH)	WIND SPEED 21M/S (75.6KPH)	WIND SPEED 23M/S (82.8KPH)	WIND SPEED 26M/S (93.6KPH)	WIND SPEED 29M/S (104.4KPH)
1.8m	90 x 45 MPG10	3+3	4+4	4+4	5+5	N/A	N/A
2.4m	90 x 45 MPG10	3+3	5+5	7+7	8+8	11+11	14+14
3m	90 x 45 MPG10	5+5	9+9	11+11	13+13	17+17	N/A
3.6m	90 x 45 MPG10	7+7	12+12	16+16	19+19	N/A	N/A
4m	90 x 45 MPG10	9+9	16+16	19+19	N/A	N/A	N/A

FREE-STANDING HOARDING OPTIONS FOR **DOUBLE STACK OF COUNTERWEIGHTS @ 0.6MW INTERVALS**

SOLID PANEL HEIGHT – MAX (H)	STUD – 90 X 45 (4X2) MPG10	WIND SPEED 15M/S (54KPH)	WIND SPEED 19M/S (68.4KPH)	WIND SPEED 21M/S (75.6KPH)	WIND SPEED 23M/S (82.8KPH)	WIND SPEED 26M/S (93.6KPH)	WIND SPEED 29M/S (104.4KPH)
1.8m	90 x 45 MPG10	3+3	3+3	3+3	3+3	4+4	4+4
2.4m	90 x 45 MPG10	3+3	3+3	4+4	4+4	6+6	7+7
3m	90 x 45 MPG10	3+3	5+5	6+6	7+7	9+9	11+11
3.6m	90 x 45 MPG10	4+4	6+6	8+8	10+10	13+13	16+16
4m	90 x 45 MPG10	5+5	8+8	10+10	12+12	15+15	19+19

See 'Lomax System Outdoor Configurator' for full range of options

Weight Stack Heights and Double Stack Safety Rod

CRITICAL REQUIREMENTS

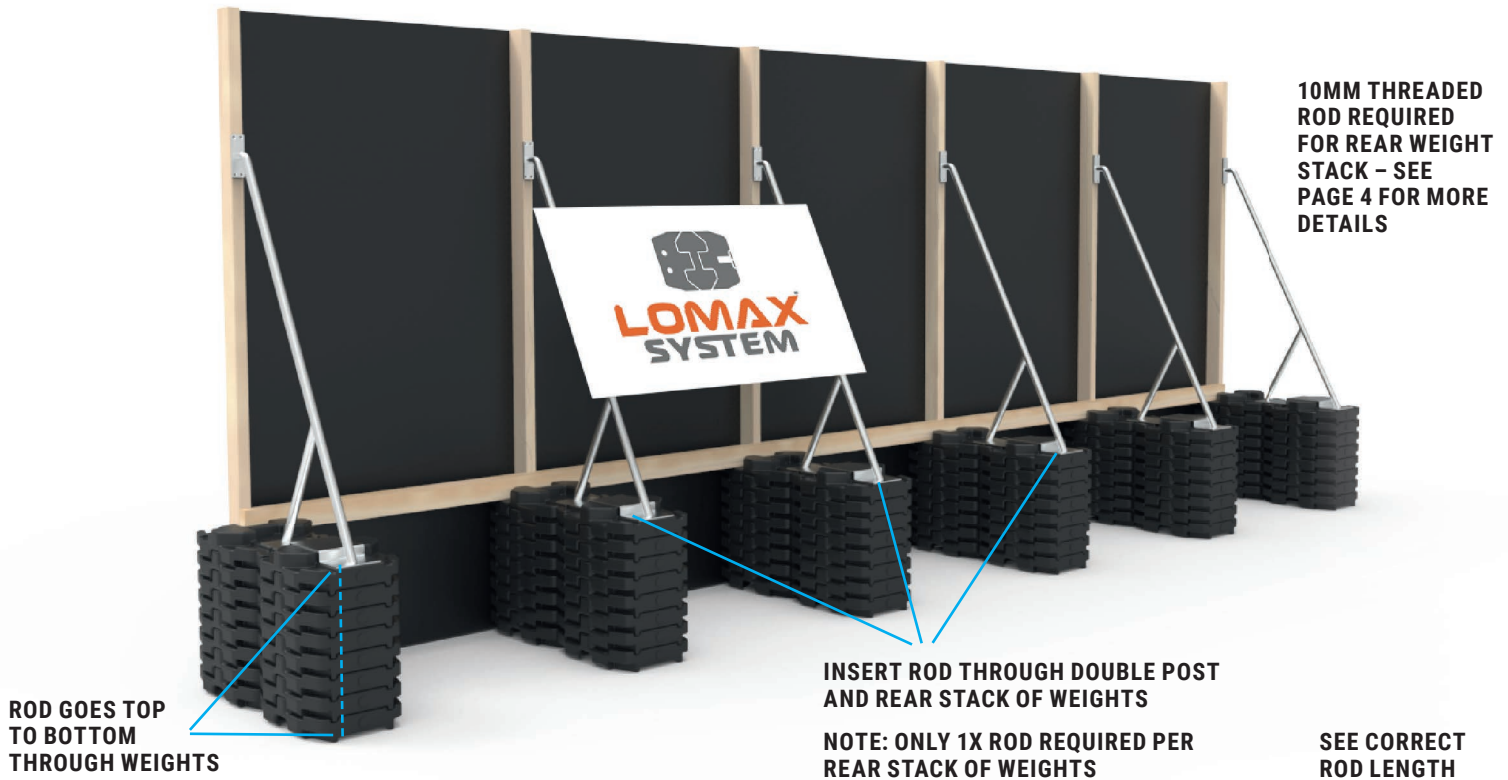

LOMAX SYSTEM WEIGHT / HEIGHT GUIDE					
18KG WEIGHTS	HEIGHT (M) WITH NO POST	HEIGHT (M) WITH DOUBLE POST	HEIGHT (M) WITH LARGE POST	HEIGHT (M) WITH SMALL POST	LENGTH REQUIRED (M) FOR DOUBLE POST SAFETY ROD
20	1.41	2.77	2.84	2.32	1.41
19	1.34	2.7	2.77	2.25	1.34
18	1.28	2.64	2.71	2.19	1.28
17	1.21	2.57	2.64	2.12	1.21
16	1.14	2.5	2.57	2.05	1.14
15	1.07	2.43	2.5	1.98	1.07
14	1	2.36	2.43	1.91	1
13	0.93	2.29	2.36	1.84	0.93
12	0.87	2.23	2.3	1.78	0.87
11	0.8	2.16	2.23	1.71	0.8
10	0.73	2.09	2.16	1.64	0.73
9	0.62	1.98	2.05	1.53	0.62
8	0.6	1.96	2.03	1.51	0.6
7	0.53	1.89	1.96	1.44	0.53
6	0.41	1.77	1.84	1.32	0.41
5	0.39	1.75	1.82	1.3	0.39
4	0.35	1.71	1.78	1.26	0.35
3	0.3	1.66	1.73	1.21	0.3
Large Post Height Addition (m) = 1.43		Small Post Height Addition (m) = 0.91		Double Post Height Addition (m) = 1.36	

Lomax® – ‘Safe Pedestrian Zone’ Fencing Solution



LOMAX FENCING SYSTEM (INSTALLATION GUIDE)

1. Stack counterweights as per guide below
2. Insert standard 32mm OD fencing panel posts into post holes
3. Insert Lomax Fencing Support Post with integrated panel clamp
4. Stacks are placed inside to create a 'Safe Pedestrian Zone' outside the fence
5. Place stacks at a 45 degree angle to create a corner

STRUCTURAL ENGINEERING TESTING – SAMPLE GUIDE FOR FENCING CONFIGURATIONS AND COUNTERWEIGHT OPTIONS

Configurations below are derived from numerous site-specific example configurations for Topography Multiplier | Shielding Class | Terrain Category | Shade Cloth
(Multiple alternative configurations are available – Your individual site specific location and conditions must be considered before deployment)

	Climb Test Pass (Y/N)	Impact Test Pass (Y/N)	Aperture Test Pass (Y/N)	Stability Class 15m/s (54Kph)	Stability Class + 30% Shade Cloth	21m/s (75.6Kph)	24m/s (86.4Kph)	27m/s (97.2Kph)	30m/s (108Kph)	33m/s (118.8Kph)	36m/s (129.6Kph)	39m/s (140.4Kph)
Base System	Y	Y	Y	Y	-	-	-	-	-	-	-	-
Base System + 1 x Saddle Weight	Y	Y	Y	-	Y	-	-	-	-	-	-	-
Base System + 2 x Saddle Weight	Y	Y	Y	-	-	Y	Y	-	-	-	-	-
Base System + 3 x Saddle Weight	Y	Y	Y	-	-	-	-	Y	-	-	-	-
Base System + 4 x Saddle Weight	Y	Y	Y	-	-	-	-	-	Y	Y	-	-
Base System + 5 x Saddle Weight	Y	Y	Y	-	-	-	-	-	-	-	Y	Y

Note: Base System = 2 x Lomax Full-Sized 18Kg Counterweights + 1 x Lomax Fencing Support Post every fence panel join @ max 2.4mW intervals. Saddle Weight = 30Kg
Fence panel used for testing was: RapidMesh 240x210cm 32mm OD Light-guage Galvanised Steel Temp Fence Panel

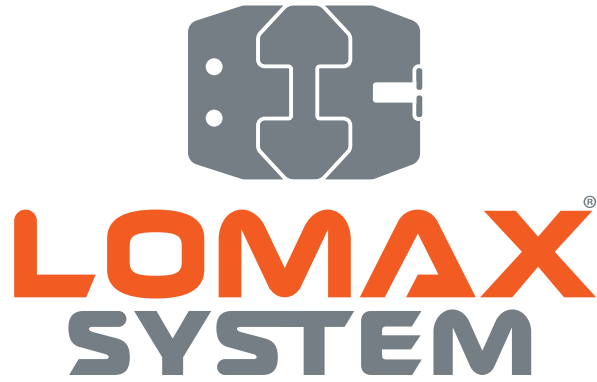

SAFETY PRECAUTIONS / CHANGES OF ENVIRONMENT

As the purchaser and responsible installer of the various components of the 'Lomax System' it is paramount that due consideration is given to the location of any installation and that the appropriate system configuration deployed is fit for purpose. This consideration should include not only the existing location being considered but also any potential changes to that location that may occur during the lifecycle of the installation. **FOR EXAMPLE:** If a hoarding is being installed into an indoor location with the correct system configuration, then proper consideration should be made to understand if any 3rd party or external factors may be altered during the hoardings' lifecycle that may possibly expose the hoarding to outdoor wind pressures. As an example, these changes could include removal of external walls or activations of base build exhaust systems and as such these additional factors should be considered when selecting the correct system configuration. The purchaser and installer are the responsible party to consider these factors so as to select the correct system configuration for existing and possible future site conditions.

GENERAL TERMS AND CONDITIONS

HOARDING: The intent of this document is to clearly describe and illustrate the build process and structural certification parameters of the various indoor and outdoor modular configurations for the Lomax System. Particular attention should be given to the screw type, screw spacing required and correct configuration selection based on both existing location factors and possible changes to those factors (such as wind impacts). **FENCING:** Due to the external nature of fencing installations that vary by location, wind levels, shade-cloth & signage requirements, no single guide can meet all scenarios. As such, these images are general and for illustration purposes only and additional guidance should be sought to ensure compliance prior to installation. **GENERAL:** By signing this Technical Guide, you as the purchaser and responsible installer confirm your understanding of the details within and acknowledge that any variation ensures that pre-certified compliance no longer applies.

For any additional information or further details on system features, suitable configurations, product info please contact Lomax System Pty Ltd directly.

YOUR NAME:

COMPANY NAME YOU REPRESENT:

PLEASE SIGN HERE IN FULL **DATE**

to acknowledge you have read and understood this document and that you will ensure that all staff, contractors or associated parties of the company you are representing will act in accordance to this document